



PROJECT _____

ITEM NO: _____

QUANTITY: _____

Underbar Drainboards

FEATURES & CONSTRUCTION:

- Corrugated top is fabricated with 1" flat front edge with 3" high flat top backsplash.
- 1" L.P.S drain pipe at top.
- All exposed welded areas smooth polished to brush finish sanitary #4.
- Welded Stainless Steel leg socket with two point leg fastening.
- Adjustable galvanized steel cross-bars with aluminum die cast fittings to secure cross-bars to legs for added stability.
- All units shipped K.D., but easily assembled.

MATERIAL:

- Top: 18 Ga. stainless steel - 304
- Front & Back: 18 Ga. stainless steel - 304
- Both Side: 18 Ga. stainless steel - 304
- Leg: 1-5/8" galvanized steel
- Cross-bar: 1-1/4" galvanized steel
- Bullet Feet: 1" adjustable plastic bullet feet



SMBD-24

| MODEL# | UNIT SIZE | | | DRAIN LOCATION |
|---------|-----------|-----|-----|----------------|
| | L | D | H | |
| SMBD-12 | 12" | 18" | 30" | |
| SMBD-18 | 18" | | | |
| SMBD-24 | 24" | | | |
| SMBD-30 | 30" | | | |
| SMBD-36 | 36" | | | |
| SMBD-48 | 48" | | | |

SMBD-12 SMBD-18 SMBD-24 SMBD-30 SMBD-36 SMBD-48 COMMON SIDE VIEW

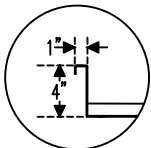
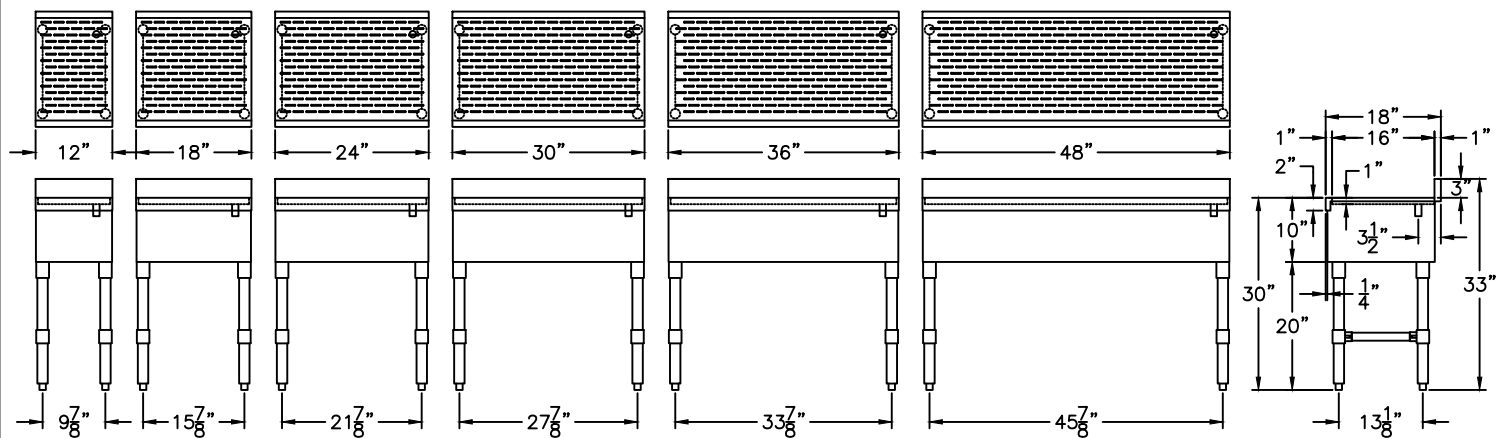

1"x4" high Backsplash

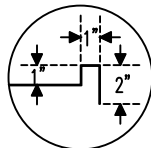

Square Edge Front



Aluminum Die Cast Fitting For Adj. Cross-Bar



1" L.P.S Drain Pipe



1" Adjustable Plastic Bullet Feet



NSF STD.2 Certified

Specifications subject to change without notice.

All dimensions are typical (Tolerance 1/2").



Rev. 06/22

SAPPHIRE MANUFACTURING
Tel: 718-543-2111
Fax: 718-543-2121

info@sapphiremanufacturing.com
WWW.SAPPHIREMANUFACTURING.COM